

Remuneration Plan for Icing On The Cake (Uni-Level)

There are 2 types of Bonus in IOC plan, which is Uni-Level Bonus and Icing Profit Sharing Bonus.

1. Uni-Level Bonus (5 – 15%)

The Uni-Level Bonus will be calculated from **1st to 11th level NEW** iMember Downlines based on following formula:

Level of iMember	Bonus
1 st Level	iSV x 15%
2 nd Level	iSV x 10%
3 rd Level	iSV x 5%
4 th Level	iSV x 5%
5 th Level	iSV x 5%
6 th Level	iSV x 5%
7 th Level	iSV x 5%
8 th Level	iSV x 5%
9 th Level	iSV x 5%
10 th Level	iSV x 5%
11 th Level	iSV x 5%

• Rules of Uni-Level Bonus

1. To be entitled for the Uni-Level Bonus, iMember needs to have any downline (existing/new members) under 1st to 11th level to join the IOC plan.
2. Each iMember may purchase more than one iPackage, with the following conditions:
 - i) 1st pack must be placed under the upline as in existing Marketing Plan hierarchy. If the direct upline is not joining the IOC plan, the system will automatically define the nearest upline as his/her upline. Same for the Uni-level Sales Value (iSV), it will be compressed to the nearest upline from 1st to 11th level.
 - ii) For the following iPackage purchased (2nd pack onwards), iMember may choose to place the additional pack any of his own specific iCodes other than his 1st iCode. Any downlines in IOC under 2nd iCode should be a new iMember in the particular month (before icing bonus processing) who have joined as DXN member after the implementation of IOC.
3. If an iMember wish to place his/her new downline under his other iCodes other than his own 1st iCode, he must define the iUpcode during the registration of IOC. Otherwise IOC system will automatically place the said new downline under the 1st iCode.

4. The hierarchy of IOC will be compressed and not fixed during each bonus process. Members are allowed to join at their own position based on existing marketing plan hierarchy at any time they wish. The hierarchy will not be affected although his downline has joined earlier.

5. If a member did not join this plan, the IOC bonus based on the iSV shall be passed over to those uplines who already joined according to the compressed hierarchy. If at any later stage this member joins to this plan, he will get the bonus from his newly joined downlines in his group thereafter.

6. Only iSV from new iMembers will be counted for each bonus process, meaning that the iSV used to calculate Uni-Level Bonus will be counted based on the total **new** iMember who joined IOC at that particular month (monthly iSV cut off).

7. There is no any qualification or monthly maintenance needed to entitle for this bonus.

2. Icing Profit Sharing (1.5%)

The Icing Profit Sharing Fund will be accumulated and calculated from all **NEW** iMembers based on the following formula:

$$\text{Icing Profit Sharing Fund} = \text{Total New iMembers} \times \text{iSV Value} \times 1.5\%$$

Percentage of Icing Profit Sharing (%) =

$$\frac{\text{No. of New iMember Downlines from 12}^{\text{th}} \text{ Level onward}}{\text{Total New iMember Downlines of each Participating iMember (from 12}^{\text{th}} \text{ Level onward)}} \times 100$$

Your iPS entitlement,

$$\text{Icing Profit Sharing (iPS)} = \text{Icing Profit Sharing Fund} \times \text{Percentage of Icing Profit Sharing (\%)}$$

● Rules of Profit Sharing

1. All iMembers who have NEW iMember Downline from 12th level onward will be entitled for the Icing Profit Sharing Bonus.

2. iPS Fund will be accumulated from all new iMembers who joined during the 6 months fiscal period. The respective iSV of all the new iMember Downlines of each participating iMembers from 12th level onward will be counted and added up.

3. iPS Fund will be accumulated and to be cut off every 6 months. iPS fund will not be carried forward to the next fiscal period.
4. iPS Fund for new iMembers (12th level onward) from different countries will be converted into one standard currency before proceed to iPS calculation .
5. iPS will be paid in every 6 months. DXN may change/extend the 6 months period of the iPS without prior communication and consent from members.

Illustration

** Assume that the Europe iPackage (Scheme 200, iSV 100) will be used for all following Bonuses calculation*

1. Uni-Level Bonus (5 – 15%)

Your Uni-Level Bonus entitlement,

Level	iSV 100 (EU)	Bonus Calculation	Bonus (EURO)
1	100	15% x 100	15
2	100	10% x 100	10
3	100	5% x 100	5
4	100	5% x 100	5
5	100	5% x 100	5
6	100	5% x 100	5
7	100	5% x 100	5
8	100	5% x 100	5
9	100	5% x 100	5
10	100	5% x 100	5
11	100	5% x 100	5

Case 1:

If you have 1 line as below :

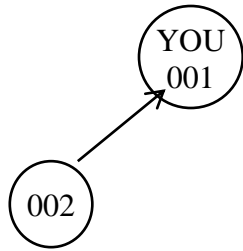

Uni-Level Bonus for iCode : **001**

Level	Uni-Level	Bonus
1	'002	100 iSV x 15%

Therefore,

Your Uni-Level Bonus is EURO 15

Case 2:

If you have 2 lines as below :

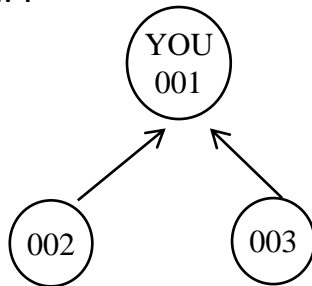

Uni-Level Bonus for iCode : **001**

Level	Uni-Level	Bonus
1	'002, '003	100 iSV x 15% 100 iSV x 15%

Therefore,

Your Uni-Level Bonus is EURO 15 + EURO 15 = EURO 30

Case 3:

Members are allowed to reserve the position based on existing Marketing Plan hierarchy

Existing Marketing Plan Hierarchy

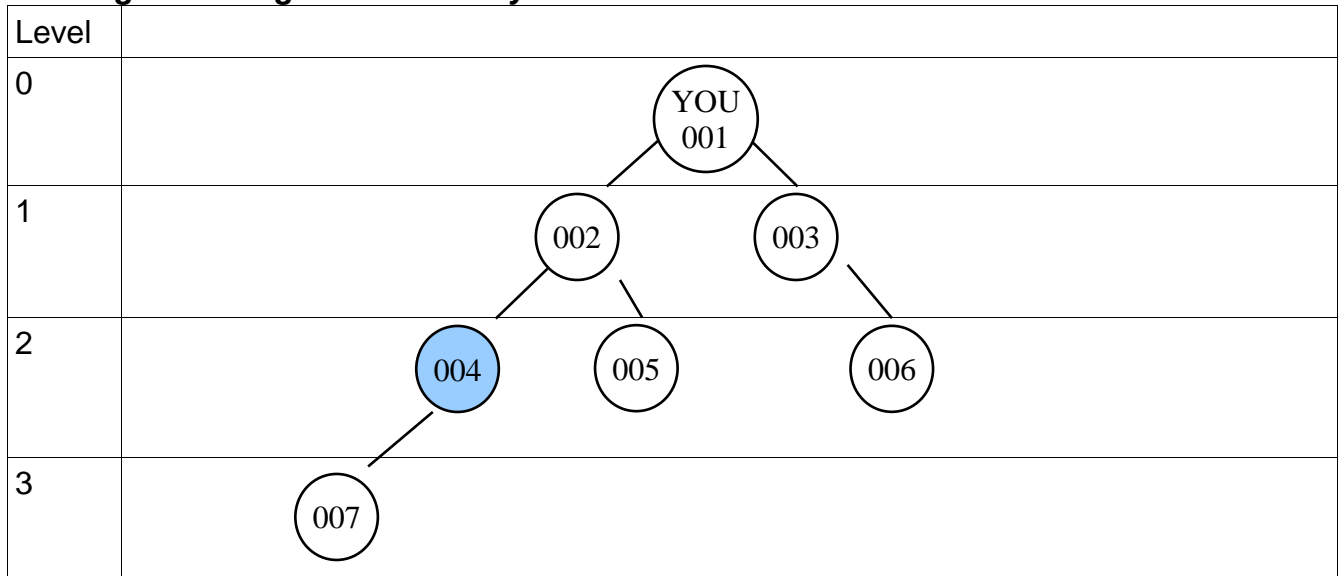

Icing Hierarchy

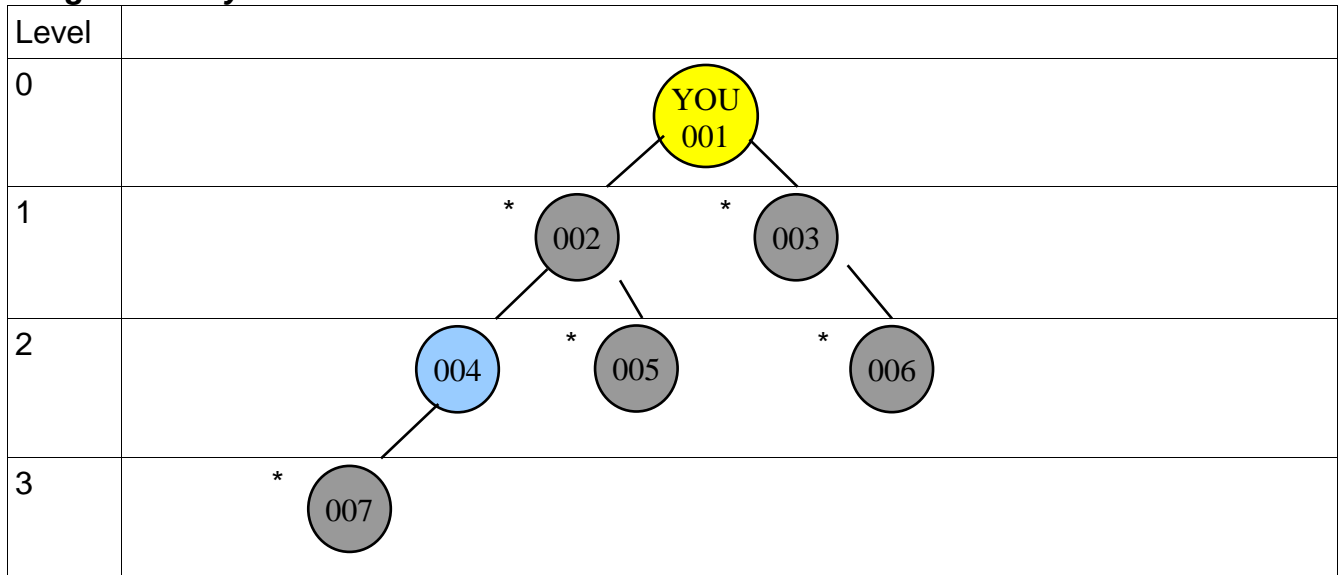

Table 1.0

* = iMember who already joined IOC earlier

- 004 who join later is allowed to remain the position same as existing Marketing Plan hierarchy.
- 004 will not entitle for any Uni-Level Bonus from 007 as 007 joined earlier.
- YOU (001) and 002 will entitle for Uni-Level Bonus from 004.
- No impact to the 003, 005 and 006.

Uni-Level Bonus for iCode : **001**

Level	Uni-Level	Bonus
2	'004	100 iSV x 10%

Uni-Level Bonus for iCode : **002**

Level	Uni-Level	Bonus
1	'004	100 iSV x 15%

Therefore,

Your Uni-Level Bonus is EURO 10

Uni-Level Bonus for 002 is EURO 15

Case 4:

No carry forward iSV and iSV will be cut off on monthly basis

Month 1

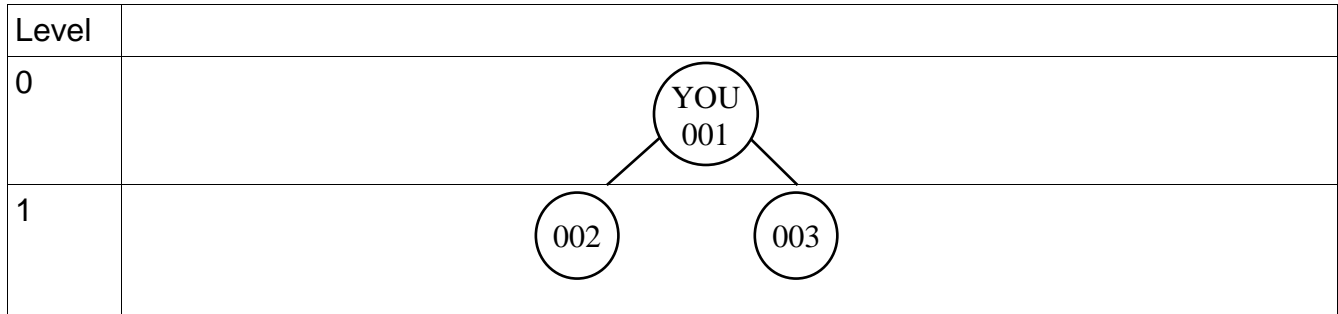

- YOU (001) will entitle for Uni-Level Bonus from 002 and 003

Uni-Level Bonus for iCode : **001**

Level	Uni-Level	Bonus
1	'002, '003	100 iSV x 15% 100 iSV x 15%

Therefore,

Your Uni-Level Bonus is EURO 15 + EURO 15 = EURO 30

Month 2

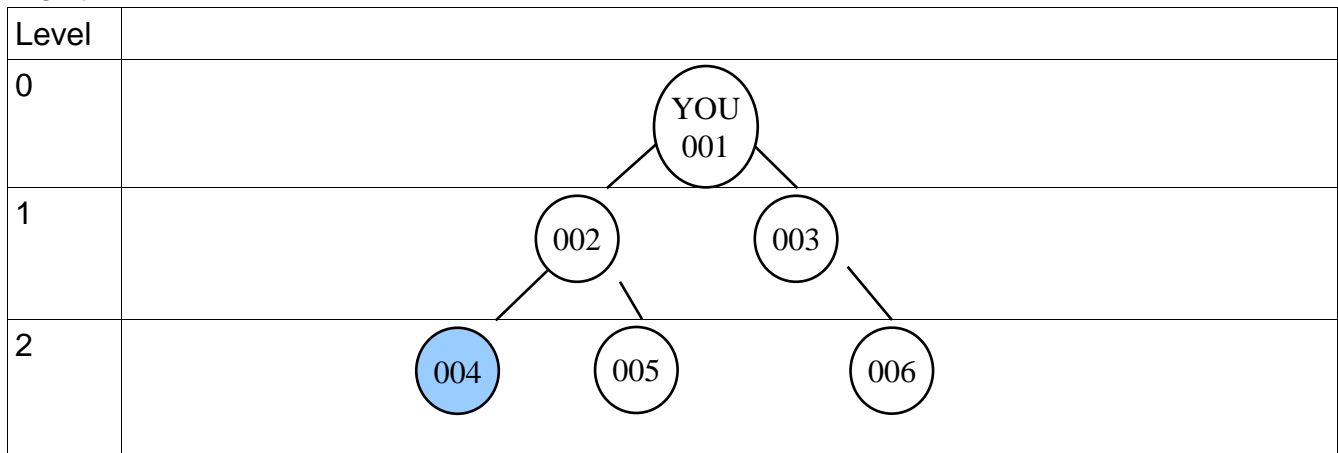

- 002 and 003 will not be counted again in Month 2
- Only 004, 005 and 006 will be counted
- 002 will entitle for 1st level Uni-Level Bonus from 004 and 005

- 003 will entitle for 1st level Uni-Level Bonus from 006
- YOU (001) will entitle for 2nd level Uni-Level Bonus from 004, 005 and 006

Uni-Level Bonus for iCode : **001**

Level	Uni-Level	Bonus
1	-	No Bonus
2	004, 005 and 006	100 iSV x 10% 100 iSV x 10% 100 iSV x 10%

Uni-Level Bonus for iCode : **002**

Level	Uni-Level	Bonus
1	004 and 005	100 iSV x 15% 100 iSV x 15%

Uni-Level Bonus for iCode : **003**

Level	Uni-level	Bonus
1	'006	100 iSV x 15%

Therefore,

Your Uni-Level Bonus is EURO 10 + EURO 10 + EURO 10 = EURO 30

Uni-Level Bonus for 002 is EURO 15 + EURO 15 = EURO 30

Uni-Level Bonus for 003 is EURO 15

Case 5:

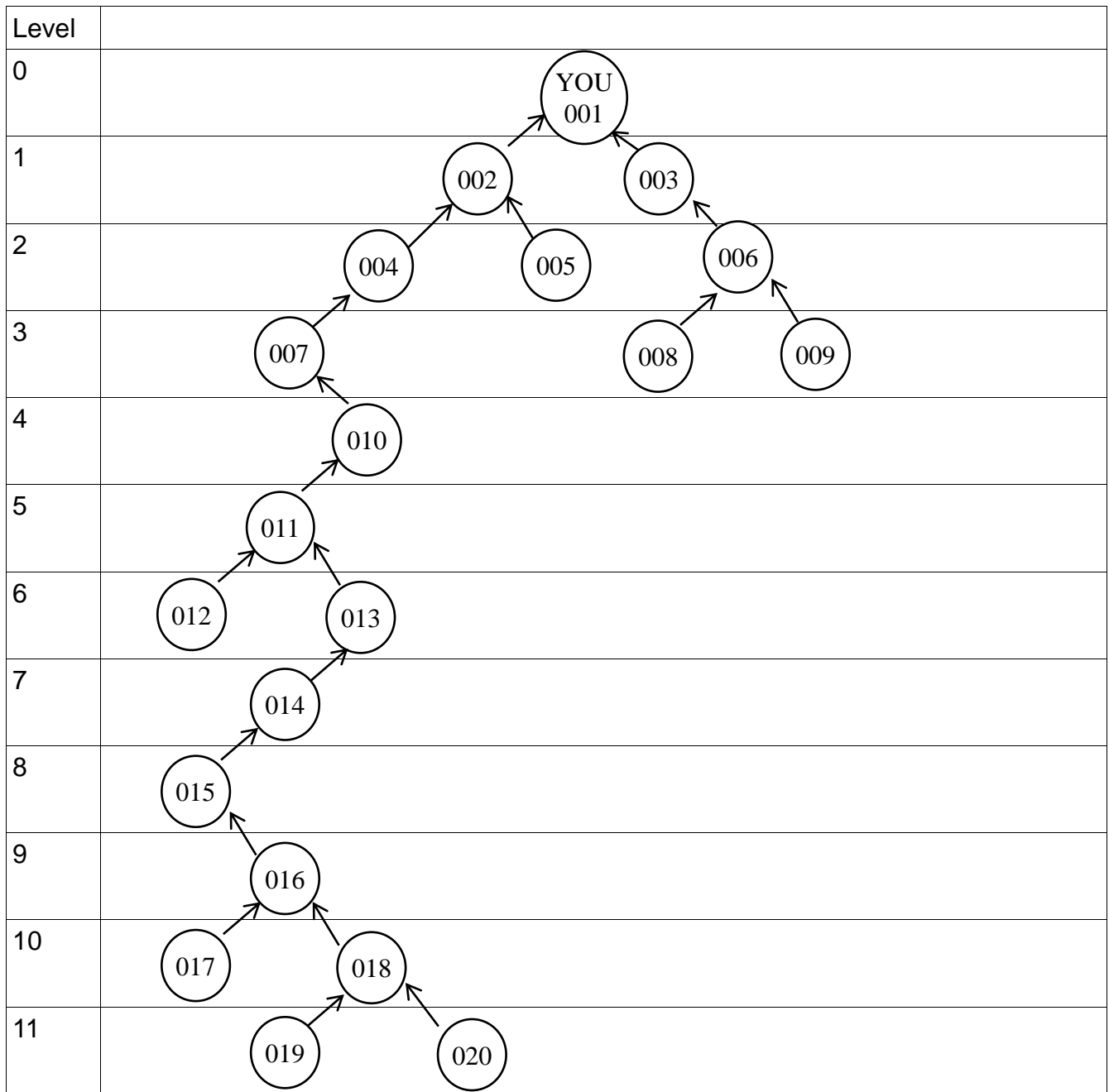

Uni-level Bonus calculation for icode : **001**

1st Level:

Level	iCode
1	'002, '003

002 : 100 iSV x 15% = EURO 15

003 : 100 iSV x 15% = EURO 15

2nd Level:

Level	iCode
2	'004, '005, '006

004 : 100 iSV x 10% = EURO 10

005 : 100 iSV x 10% = EURO 10

006 : 100 iSV x 10% = EURO 10

3rd to 11th Level:

Level	Icode
3	'007, '008, '009
4	'010
5	'011
6	'012, '013
7	'014
8	'015
9	'016
10	'017, '018
11	'019, '020

007 : 100 iSV x 5% = EURO 5

008 : 100 iSV x 5% = EURO 5

009 : 100 iSV x 5% = EURO 5

010 : 100 iSV x 5% = EURO 5

011 : 100 iSV x 5% = EURO 5

012 : 100 iSV x 5% = EURO 5

013 : 100 iSV x 5% = EURO 5

014 : 100 iSV x 5% = EURO 5

015 : 100 iSV x 5% = EURO 5

016 : 100 iSV x 5% = EURO 5

017 : 100 iSV x 5% = EURO 5

018 : 100 iSV x 5% = EURO 5

019 : 100 iSV x 5% = EURO 5

020 : 100 iSV x 5% = EURO 5

Therefore,

Your Uni-Level Bonus is EURO 130

2. Icing Profit Sharing (1.5%)

Case 1:

Only from Level 12th onwards (paid every 6 months)

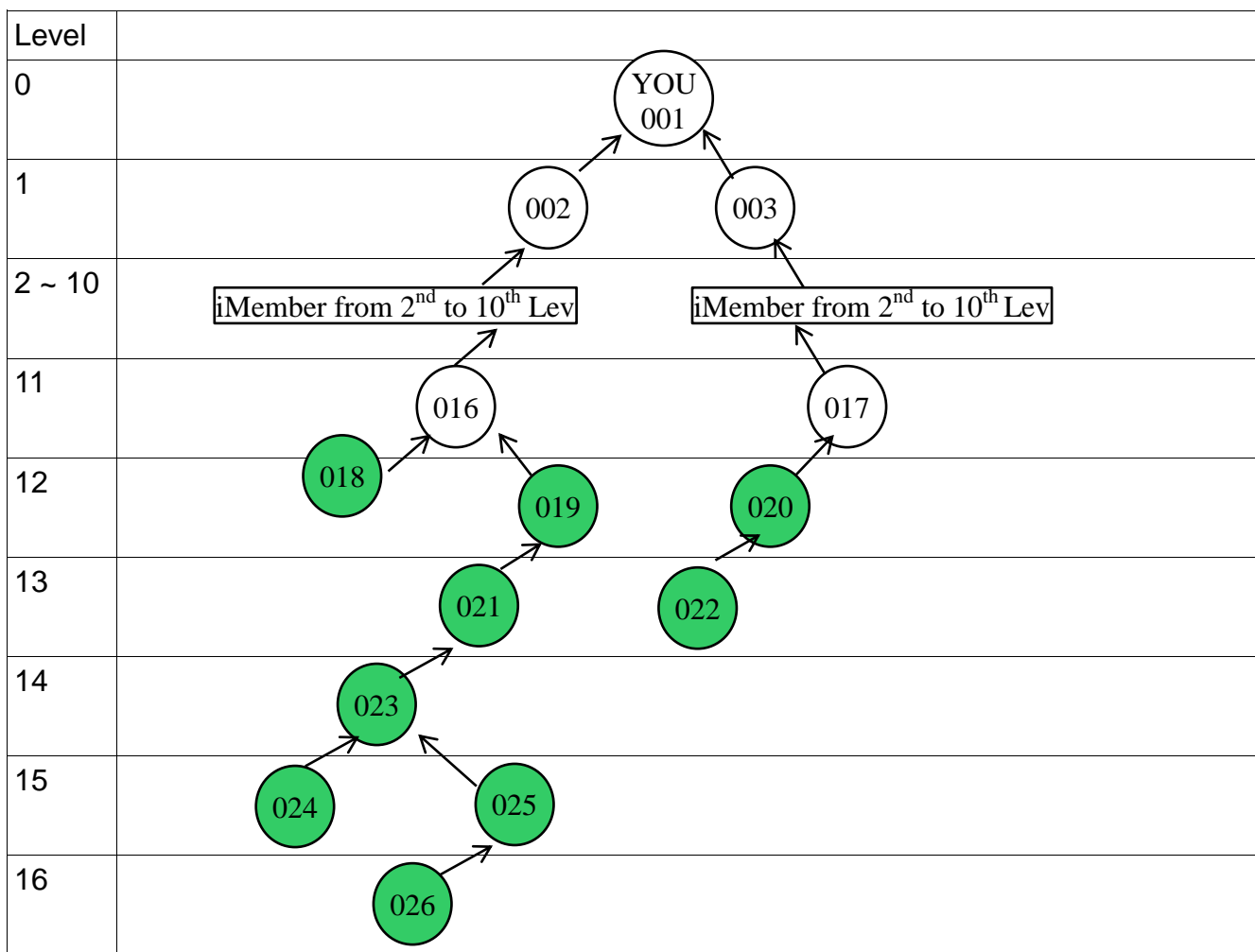

Total New iMembers, **A**: (018, 019, 020, 021, 022, 023, 024, 025, 026) = 9

New iMember Downline from 12th Level onward for **YOU, 001**: 018, 019, 020, 021, 022, 023, 024, 025, 026

New iMember Downline from 12th Level onward for **002**: 021, 023, 024, 025, 026

New iMember Downline from 12th Level onward for **003**: 022

New iMember Downline from 12th Level onward for **YOU, 001 (B1)** = 9
 New iMember Downline from 12th Level onward for **002 (B2)** = 5
 New iMember Downline from 12th Level onward for **003 (B3)** = 1

Icing Profit Sharing Fund, **C** = Total New iMembers x iSV Value x 1.5%
 = A x iSV Value x 1.5%
 = 9 x 100 iSV x 1.5%
 = EURO 13.50

Percentage of Icing Profit Sharing (%) =

$$\frac{\text{No. of New iMember Downlines from 12}^{\text{th}} \text{ Level onward}}{\text{Total New iMember Downlines of each Participating iMember (from 12}^{\text{th}} \text{ Level onward)}} \times 100$$

Percentage of Icing Profit Sharing (%)

For **YOU, 001 (D1)** = $[B1 / (B1+B2+B3)] \times 100\%$
 = $[9 / (9+5+1)] \times 100\%$
 = 60 %

For **002 (D2)** = $[B2 / (B1+B2+B3)] \times 100\%$
 = $[5 / (9+5+1)] \times 100\%$
 = 33.33 %

For **003 (D3)** = $[B3 / (B1+B2+B3)] \times 100\%$
 = $[1 / (9+5+1)] \times 100\%$
 = 6.67 %

iPS entitlement

For **YOU, 001** = Icing Profit Sharing Fund x Percentage of Icing Profit Sharing (%)
 = C x D1
 = EURO 13.50 x 60%
 = EURO 8.10

For **002** = C x D2
 = EURO 13.50 x 33.33 %
 = EURO 4.50

For **003** = C x D3
 = EURO 13.50 x 6.67 %
 = EURO 0.90

Therefore,

Your Icing Profit Sharing is EURO 8.10

Icing Profit Sharing for 002 is EURO 4.50

Icing Profit Sharing for 003 is EURO 0.90